



## Typical Specifications for DynaFlame Heating – Non-Condensing Models DF(N,P)H 0500-6004, Stainless Steel

The hydronic heating boiler shall be a CAMUS DYNAFLAME model \_\_\_\_\_ having an input rating of \_\_\_\_\_ BTU (kW)/hr. and \_\_\_\_\_ BTU (kW)/hr. output for hydronic heating.

The hydronic heating boiler shall be design certified by CSA International and shall meet the requirements of ANSI Z21.13, and CSA 4.9. The hydronic heating boiler shall be vented as a Category I or III non-condensing appliance. The boiler shall comply with the energy efficiency requirements of the latest edition of ASHRAE 90.1 standard

### Performance Overview:

- Boiler shall operate up to 85% thermal efficiency
- Heat exchanger shall be cylindrical 36 tube (Models 500 – 1200), 60 tube (Models 1500 – 2500), 72 tube (Models 3000 – 3500), 78 tube (Models 4000 – 5000) and 96 tube (Models 4504 – 6004) SA268 439 stainless steel alloy tubes, with SA240 304/316L stainless steel headers and all gasket-less sealed design.
- Fine-tuned combustion premix providing homogeneous air and gas combustion mix to a radial burner incorporating a knitted stainless steel wrap ensuring stable light off and efficient clean combustion.
- 3:1 gas input turn down ratio with sustained efficient combustion characteristics throughout entire modulating range
- Oxides of Nitrogen (NOx) of 9 ppm maximum, corrected to 3% oxygen.
- Category I venting certification with Category I and Category III available
- The boiler is fully factory fire tested to obtain optimum combustion characteristics and to establish certified gas input rates.
- System safety and operating devices and controls are fully configured, calibrated and factory tested.
- Models consist of an input range of 500 MBTUH to 6000 MBTUH
- The boiler shall comply with the energy efficiency requirements of the latest edition of the ASHRAE 90.1 Standard

### Combustion Chamber:

The combustion chamber shall be constructed of stainless steel, sealed water tight, chamber to be covered with minimal ¼" thick ceramic insulation. A stainless steel access door shall be provided for ease of service and inspection to the outer heat exchanger surface and an easily removable radial fired knitted fiber stainless steel burner to access the internal combustion chamber for inspection, service, and cleaning. A window view port shall be provided for visual inspection of the boiler combustion during firing.

### Heat Exchanger:

The heat exchanger shall be tested and inspected to A.S.M.E. Section IV requirements. The A.S.M.E. Section IV seal of approval will not be provided as standard for jurisdictions not requiring the A.S.M.E. Section IV seal of approval. The heat exchanger shall be a six pass design with a maximum working pressure of 160psig (1100kPa). The heat exchanger shall be of 439 grade stainless steel welded construction with a vertical cylindrical counter-flow, water tube design, complete with integral 439 stainless finned heater transfer tubes and 304/316L waterways.

### Gas Train:

The gas train shall consist of a pressure regulating electro-hydraulic proportional air/gas main gas actuator providing a slow opening, fast closing shutoff valve and proportional 1:1 air/gas ratio control, a fast closing safety shutoff gas solenoid, and a low gas pressure switch. Optional high gas pressure switch is available. A factory pre-set combination metering valve and orifice shall be provided for setting combustion parameters. Models DF 500 – DF 6004 operate with a 3:1 turndown ratio.

### Burner/Combustion:

The combustion air fan draws gas under negative pressure and mixes it with air to generate a fine tuned air gas mixture which is delivered under positive pressure to the radial knitted stainless steel burner. Combustion modulation is established by a variable frequency drive on all models. The burner shall be a 100% stainless steel vertical mounted radial fired type with stainless knitted metal fiber construction. The burner shall combust a precise amount of premixed combustion air and gas to provide equal distribution of heat for heat transfer throughout the entire heat exchanger. Combustion products are exhausted under minimum back pressure. Combustion operates with a 3:1 turn down ratio while sustaining combustion characteristics throughout the entire modulating range. Operation of up to 85% thermal efficiency and shall be certified for Oxides of Nitrogen (NOx) of 9 ppm corrected to 3% oxygen.

### Firing Mode:

The burner combustion shall operate as proportional modulating with a 3:1 turndown ratio with a minimum 35% firing rate. Multiple boiler "Cascade" firing algorithms are proportional modulation. Light off shall be at no more than 50% input to assure rumble free soft start. Combustion shall be optionally suitable for natural gas, propane and dual fuels operation.



## Typical Specifications for DynaFlame Heating – Non-Condensing Models DF(N,P)H 0500-6004, Stainless Steel

### Controls:

Standard controls include a SOLA electronic proportional integrated combination ignition limit/operator control accurate to 1<sup>0</sup>F (0.5<sup>0</sup>C) having a 4-20 mA output signal suitable for control of a variable frequency motor drive for modulating fan speeds. Controls are lead lag "Cascade" ready for control of up to eight boilers c/w Indoor outdoor reset. Control shall be equipped and ready with 4-20 mA or 2-10Vdc input for remote set point or modulating control. Control is BMS Modbus RTU protocol ready and capable of other alternate protocol conversions with additional optional gateway protocol converter. Control shall be supplied with a 7" mounted touch screen display which shall also provide for control system configuration and set up, readouts of boiler target, differential and inlet/outlet temperatures as well as accumulated runtime, enunciator diagnostics, and firing rates. The display shall include real time data logging and support for up to eight (8) boilers. The complete control package shall be mounted on the front panel with a hinged door for easy access to all control modules. The boiler safety control string shall be furnished with controls for low gas pressure, fan air proving, blocked flue, high limit and flow switch. High gas pressure switch is standard on CSD1 equipped boilers and is standard on models 3000 and up. A flow switch and relief valve shall be provided for each unit. Additional control safeties shall include flame rectification, fan speed, and auto recycling high limit.

### Ignition Module:

The ignition module shall employ a direct igniter with 3 tries for ignition followed by lockout for DF 500 - DF 2500. A proven pilot is used on DF 3000 – DF 6004. Trial for ignition shall proceed with 15 seconds between retrials. Ignition control shall include times for pre-purge, pre-ignition, ignition, and post purge.

### Venting Options:

The following venting options shall be utilized:

- Category I Venting – single or combined vent
- Category III Outside Air (Horizontal & Vertical)
- Category III Through-wall Venting (Horizontal & Vertical)
- Outdoor Venting
- Category I & III Direct Venting

The following Category I vent material shall be utilized:

- 'B' type or 'C' type
- Stainless steel single-wall, where field conditions are likely to result in condensation in the vent

The following Category III vent material shall be utilized:

- Stainless or AL29-4C material, single or double wall, positive pressure rated

### External Jacket and Fasteners:

The external jacket shall be of 430 stainless steel mirror finish panels and a powder paint coated access top cover assembled utilizing interference fit locks and minimal non-strip self tap screws for ease of removal and access to the heat exchanger and combustion air / gas control.



**Typical Specifications for DynaFlame Heating – Non-Condensing Models DF(N,P)H 0500-6004, Stainless Steel**

Engineer: \_\_\_\_\_ Job Location: \_\_\_\_\_ Date: \_\_\_\_\_  
 Prepared by: \_\_\_\_\_ Buyer's Name: \_\_\_\_\_ Quote #: \_\_\_\_\_  
 Job Name: \_\_\_\_\_ Buyer's Address: \_\_\_\_\_

**DYNAFLAME 0500-1200**

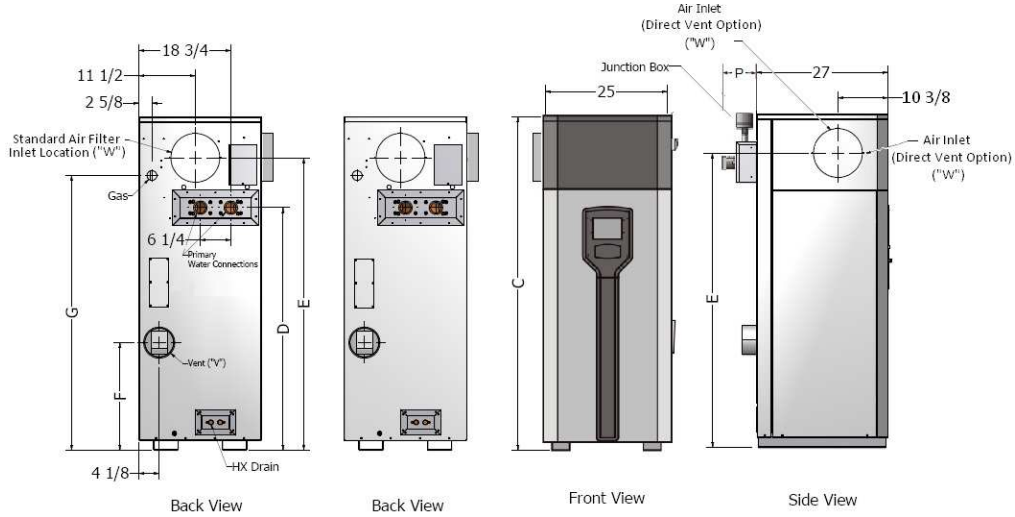

**DYNAFLAME 1500-5000**

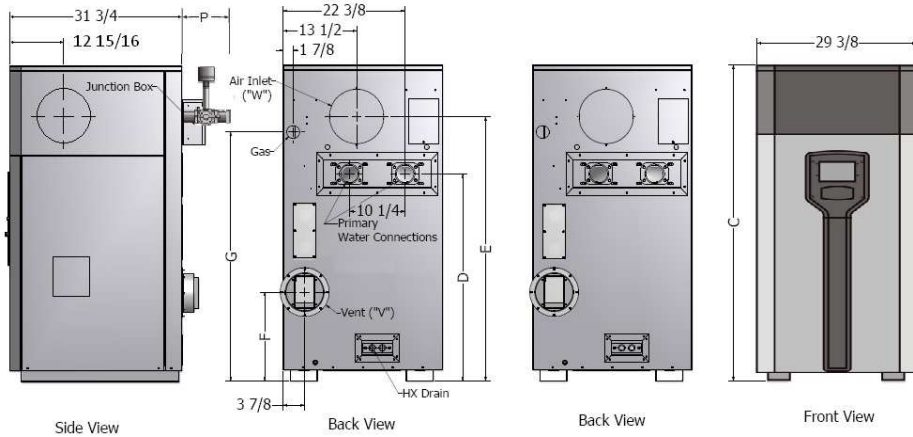

**DYNAFLAME MEGA 4504-6004**

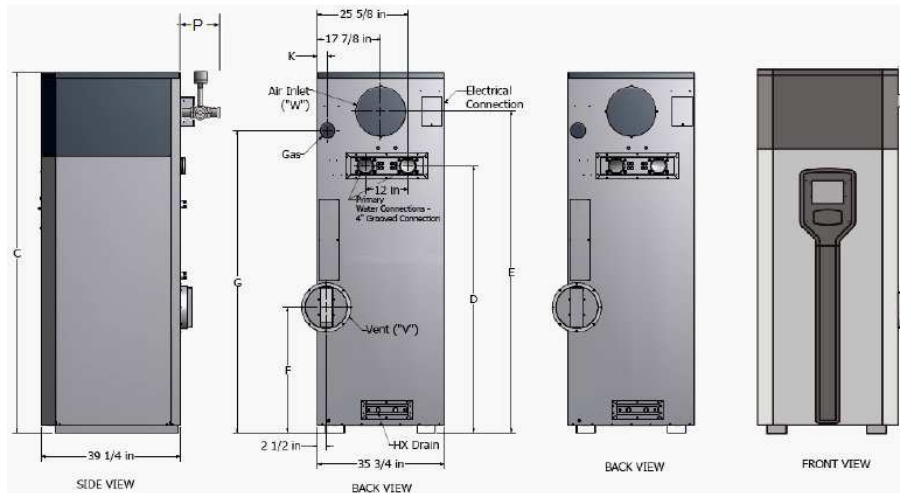



## Typical Specifications for DynaFlame Heating – Non-Condensing Models DF(N,P)H 0500-6004, Stainless Steel

### Dimensions

Model	Height Dim.	Water Conn.	Air Inlet "E" [in.]	Flue Height "F"	Gas Height "G"	Air Inlet Dia.**	Dim. "P" [in.]	Water Conn.*	Gas Conn.	Dim. "K" [in.]
0500	45 5/8	27	37 1/4	13 1/4	33 5/8	6	5	2	1	--
0750	55	36 3/8	46 5/8	15 3/4	43	8	5	2	1	--
1100	68 1/4	49 5/8	59 7/8	22	56 1/4	8	5	2	1	--
1200	68 1/4	49 5/8	59 7/8	22	56 1/4	8	5	2	1	--
1500	58 1/8	38 1/4	48 5/8	16 3/8	45 7/8	10	5	2 1/2	1 1/4	--
1750	62 5/8	42 5/8	53 1/8	16 3/8	50 3/8	10	5	2 1/2	1 1/4	--
2000	66 7/8	46 7/8	57 3/8	20	53 5/8	12	5	3	1 1/4	--
2500	73 1/2	52 5/8	63 5/8	25 3/4	60 3/8	12	5 1/2	3	1 1/2	--
3000	79 1/2	58 5/8	69 5/8	31 3/4	66 3/8	12	5 1/2	3	1 1/2	--
3500	86 1/2	63 5/8	76	24 7/8	72 5/8	14	6	4	2	--
4000	91 1/2	68 5/8	81	29 7/8	77 5/8	14	6	4	2	--
4500	96 1/2	73 5/8	86	34 7/8	82 5/8	14	31	4	2 1/2	--
5000	101 1/2	78 5/8	91	39 7/8	87 5/8	14	31	4	2 1/2	--
4504	83	59 3/4	72 1/4	20 3/4	67 7/8	14	31	4	2 1/2	3 1/2
5004	88 1/4	65	77 1/2	26	72 1/4	14	31	4	2 1/2	3 1/2
6004	102	75 1/2	91	35 1/2	85 1/2	14	31	4	3	2 3/4

\*Recommended pipe size. Models 1500-5000 Appliance Inlet/Outlet Connections are 3", all units are groove-locked type.  
 \*\*Recommended size of air inlet pipe, actual air inlet opening at filter may be one size larger than shown

### Primary Heat Exchanger Head Loss and Flow

Model	Temperature Rise Across Heat Exchanger			
	20°F		30°F	
	USGPM	ΔP-Ft.	USGPM	ΔP-Ft.
0500	42.0	1.5	28.0	0.7
0750	63.0	3.0	42.0	1.4
1100	92.4	5.9	61.6	2.8
1200	102.0	4.4	68.0	2.0
1500	125.9	8.3	83.9	3.8
1750	135.0	12.5	90.0	6.0
2000	167.9	6.7	111.9	3.2
2500	209.9	8.4	139.9	3.9
3000	251.9	9.9	167.9	4.7
3500	297.2	11.8	198.1	5.6
4000	340.4	17.1	226.9	8.1
4500	382.1	28.4	254.7	13.3
5000	424.4	31.1	282.9	14.7
4504	382.1	20.4	254.7	9.7
5004	424.4	23.5	282.9	11.2
6004	509.3	38.0	339.5	18.0

### Non-Condensing Venting

Model	Vent ("V") Diameter Inches			
	Outdoor	Cat. III Up to 50 ft	Cat. III Up to 100 ft	Cat. I
0500	4	4	6	8
0750	6	6	8	10
1100	6	6	8	10
1200	6	6	8	10
1500	7	7	10	12
1750	7	7	10	12
2000	8	8	12	14
2500	8	8	12	14
3000	8	8	12	14
3500	9	9	14	16
4000	9	9	14	16
4500	10	10	14	16
5000	10	10	14	16
4524	10	10	14	16
5004	10	10	14	16
6004	12	12	14	16

### Input & Output (MBTUH)

Model	Non-Condensing	
	Input	Output
0500	500	425
0750	750	638
1100	1100	935
1200	1200	1020
1500	1500	1275
1750	1750	1488
2000	2000	1700
2500	2500	2125
3000	3000	2550
3500	3500	2975
4000	4000	3400
4500	4500	3825
5000	4999	4249
4504	4500	3825
5004	4999	4249
6004	6000	5100

### Shipping Weight (LBS)

Model	Non-Condensing
0500	520
0750	600
1100	640
1200	700
1500	825
1750	900
2000	943
2500	1,025
3000	1,100
3500	1,250
4000	1,290
4500	1,420
5000	1,627
4504	1,525
5004	1,732
6004	1,963

### Current drawn by Boiler @ 115 Volts Single Phase 60 Hz

Model	Max Amps Draw – Boiler Only
0500	7
0750	7
1100	7
1200	7
1500	11
1750	11
2000	11
2500	14

### Current drawn by Boiler @ 230 Volts 60 Hz

Model	Max Amps Draw – Boiler Only	Phase
3000	14	Single
3500	16	Single
4000	16	Single
4500	24	Single
5000	18	Three
4504	24	Single
5004	18	Three
6004	18	Three

Model #: \_\_\_\_\_ # Of Units: \_\_\_\_\_ Type of Gas: \_\_\_\_\_ Total Input \_\_\_\_\_ BTU/hr  
 Total Output \_\_\_\_\_ BTU/hr Flow \_\_\_\_\_ USGPM @ Allowable Pressure Drop \_\_\_\_\_ Ft.

Optional Accessories: \_\_\_\_\_