

SECTION A-A  
SCALE 0.09

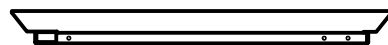
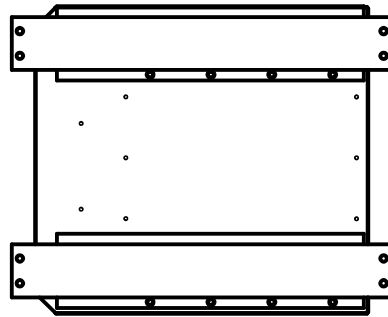

DR1600: Supplied with 8" to 7" SS vent adapter (unless specified otherwise)

THIS DRAWING REFERENCES 3D CAD FILE: 90-13700.iam REV: 00

ALL DIMENSIONS ARE IN INCHES.  
TOLERANCES UNLESS OTHERWISE STATED:  
X.X +/- 0.06"  
X.XX +/- 0.03" ANGULAR: +/- 0.5°-MACH  
X.XXX +/- 0.015" +/- 1°-BEND  
FRACTIONAL +/- 1/32"

6226 NETHERHART RD  
MISSISSAUGA, ON  
L5T 1B7  
PH: 905-696-7800  
FX: 905-696-8801



DRAWN	JHowe	9/15/2011
CHECKED		
RELEASED		
MATERIAL		FINISH NONE

DESCRIPTION	DR1600/DR1800 ASSEMBLY
-------------	------------------------

THIS DRAWING IS THE PROPERTY OF CAMUS HYDRONICS LTD. THIS DRAWING MAY NOT BE USED/COPIED WITHOUT CAMUS' PRIOR WRITTEN CONSENT.

DWG NO  
90-13700.dwg

DWG REV	00	SHEET	1 OF 1
---------	----	-------	--------