



Typical Specifications for DynaFlame DFX Heating – Near-Condensing Models DF(N,P)H 0501-6014, Stainless Steel

The hydronic heating boiler shall be a CAMUS DYNAFLAME model _____ having an input rating of _____ BTU (kW)/hr. and _____ BTU (kW)/hr. output for hydronic heating.

The hydronic heating boiler shall be design certified by CSA International and shall meet the requirements of ANSI Z21.13, and CSA 4.9. The hydronic heating boiler shall be vented as a Category II or IV near-condensing appliance. The boiler shall comply with the energy efficiency requirements of the latest edition of ASHRAE 90.1 standard

Performance Overview:

- Boiler shall operate up to 88% thermal efficiency
- Heat exchanger shall be cylindrical 36 tube (Models 501 – 1201), 60 tube (Models 1501– 2501), 72 tube (Models 3001 – 3501), 78 tube (Models 4001 – 5001) and 96 tube (Models 4514 – 6014) SA268 439 stainless steel alloy tubes, with SA240 304/316L stainless steel headers and all gasket-less sealed design.
- Fine-tuned combustion premix providing homogeneous air and gas combustion mix to a radial burner incorporating a knitted stainless steel wrap ensuring stable light off and efficient clean combustion.
- 5:1 gas input turn down ratio with sustained efficient combustion characteristics throughout entire modulating range
- Oxides of Nitrogen (NOx) of 9 ppm maximum, corrected to 3% oxygen.
- Category II venting certification with Category II and Category IV available
- The boiler is fully factory fire tested to obtain optimum combustion characteristics and to establish certified gas input rates.
- System safety and operating devices and controls are fully configured, calibrated and factory tested.
- Models consist of an input range of 500 MBTUH to 6000 MBTUH
- The boiler shall comply with the energy efficiency requirements of the latest edition of the ASHRAE 90.1 Standard

Combustion Chamber:

The combustion chamber shall be constructed of stainless steel, sealed water tight, chamber to be covered with minimal ¼” thick ceramic insulation. A stainless steel access door shall be provided for ease of service and inspection to the outer heat exchanger surface and an easily removable radial fired knitted fiber stainless steel burner to access the internal combustion chamber for inspection, service, and cleaning. A window view port shall be provided for visual inspection of the boiler combustion during firing.

Heat Exchanger:

The heat exchanger shall be tested and inspected to A.S.M.E. Section IV requirements. The A.S.M.E. Section IV seal of approval will not be provided as standard for jurisdictions not requiring the A.S.M.E. Section IV seal of approval. The heat exchanger shall be a six pass design with a maximum working pressure of 160psig (1100kPa). The heat exchanger shall be of 439 grade stainless steel welded construction with a vertical cylindrical counter-flow, water tube design, complete with integral 439 stainless finned heater transfer tubes and 304/316L waterways.

Gas Train:

The gas train shall consist of a pressure regulating electro-hydraulic proportional air/gas main gas actuator providing a slow opening, fast closing shutoff valve and proportional 1:1 air/gas ratio control, a fast closing safety shutoff gas solenoid, and a low gas pressure switch. Optional high gas pressure switch is available. A factory pre-set combination metering valve and orifice shall be provided for setting combustion parameters. Models DF 501 – DF 6014 operate with a 5:1 turndown ratio.

Burner/Combustion:

The combustion air fan draws gas under negative pressure and mixes it with air to generate a fine tuned air gas mixture which is delivered under positive pressure to the radial knitted stainless steel burner. Combustion modulation is established by a variable frequency drive on all models. The burner shall be a 100% stainless steel vertical mounted radial fired type with stainless knitted metal fiber construction. The burner shall combust a precise amount of premixed combustion air and gas to provide equal distribution of heat for heat transfer throughout the entire heat exchanger. Combustion products are exhausted under minimum back pressure. Combustion operates with a 5:1 turn down ratio while sustaining combustion characteristics throughout the entire modulating range. Operation of up to 88% thermal efficiency and shall be certified for Oxides of Nitrogen (NOx) of 9 ppm corrected to 3% oxygen.

Firing Mode:

The burner combustion shall operate as proportional modulating with a 5:1 turndown ratio with a minimum 20% firing rate. Multiple boiler “Cascade” firing algorithms are proportional modulation. Light off shall be at no more than 50% input to assure rumble free soft start. Combustion shall be optionally suitable for natural gas, propane and dual fuels operation.



Typical Specifications for DynaFlame DFX Heating – Near-Condensing Models DF(N,P)H 0501-6014, Stainless Steel

Controls:

Standard controls include a SOLA electronic proportional integrated combination ignition limit/operator control accurate to 1⁰F (0.5⁰C) having a 4-20 mA output signal suitable for control of a variable frequency motor drive for modulating fan speeds. Controls are lead lag "Cascade" ready for control of up to eight boilers c/w Indoor outdoor reset. Control shall be equipped and ready with 4-20 mA or 2-10Vdc input for remote set point or modulating control. Control is BMS Modbus RTU protocol ready and capable of other alternate protocol conversions with additional optional gateway protocol converter. Control shall be supplied with a 7" mounted touch screen display which shall also provide for control system configuration and set up, readouts of boiler target, differential and inlet/outlet temperatures as well as accumulated runtime, enunciator diagnostics, and firing rates. The display shall include real time data logging and support for up to eight (8) boilers. The complete control package shall be mounted on the front panel with a hinged door for easy access to all control modules. The boiler safety control string shall be furnished with controls for low gas pressure, fan air proving, blocked flue, high limit and flow switch. High gas pressure switch is standard on CSD1 equipped boilers and is standard on models 3000 and up. A flow switch and relief valve shall be provided for each unit. Additional control safeties shall include flame rectification, fan speed, and auto recycling high limit.

Ignition Module:

The ignition module shall employ a direct igniter with 3 tries for ignition followed by lockout for DF 501 - DF 2501. A proven pilot is used on DF 3001 – DF 6014. Trial for ignition shall proceed with 15 seconds between retrials. Ignition control shall include times for pre-purge, pre-ignition, ignition, and post purge.

Venting Options:

The following venting options shall be utilized:

- Category II Venting – single or combined vent
- Category IV Outside Air (Horizontal & Vertical)
- Category IV Through-wall Venting (Horizontal & Vertical)
- Outdoor Venting
- Category II & IV Direct Venting

The following Category II vent material shall be utilized:

- 316L Stainless Steel
- AL29-4C for all system applications

The following Category IV vent material shall be utilized:

- Stainless or AL29-4C material, single or double wall, positive pressure rated

External Jacket and Fasteners:

The external jacket shall be of 430 stainless steel mirror finish panels and a powder paint coated access top cover assembled utilizing interference fit locks and minimal non-strip self tap screws for ease of removal and access to the heat exchanger and combustion air / gas control.



**Typical Specifications for DynaFlame DFX
Heating – Near-Condensing
Models DF(N,P)H 0501-6014, Stainless Steel**

Engineer: _____ Job Location: _____ Date: _____
 Prepared by: _____ Buyer's Name: _____ Quote #: _____
 Job Name: _____ Buyer's Address: _____

DYNAFLAME 0501-1201

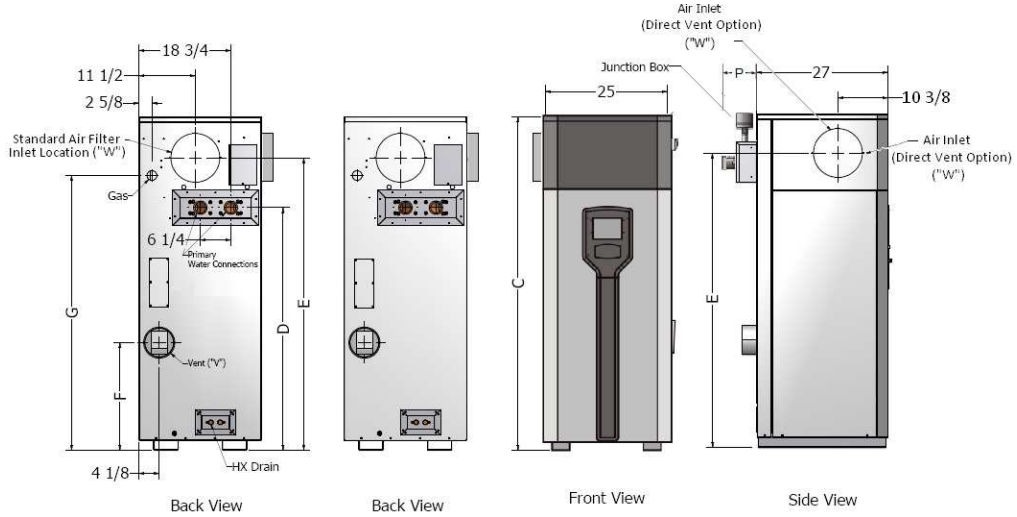

DYNAFLAME 1501-5001

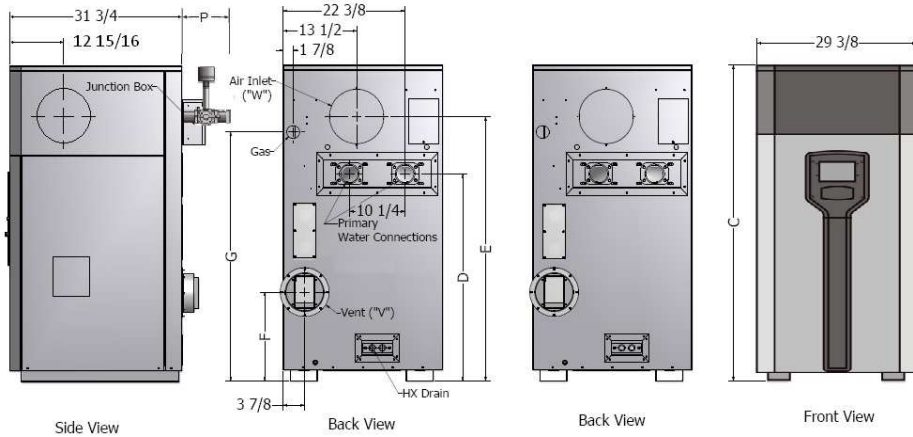

DYNAFLAME MEGA 4514-6014

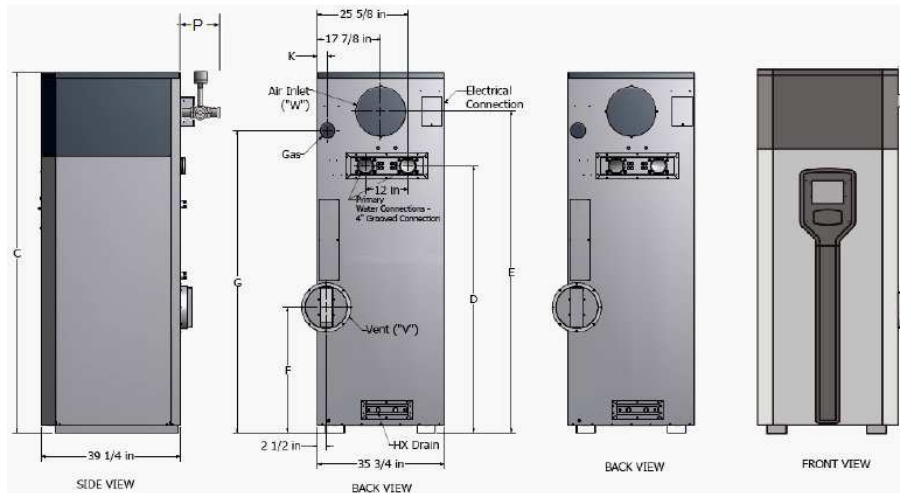



Typical Specifications for DynaFlame DFX Heating – Near-Condensing Models DF(N,P)H 0501-6014, Stainless Steel

Dimensions

Model	Height Dim.	Water Conn.	Air Inlet "E" [in.]	Flue Height "F"	Gas Height "G"	Air Inlet Dia.**	Dim. "P" [in.]	Water Conn.*	Gas Conn.	Dim. "K" [in.]
0501	45 5/8	27	37 1/4	13 1/4	33 5/8	6	5	2	1	--
0751	55	36 3/8	46 5/8	15 3/4	43	8	5	2	1	--
1101	68 1/4	49 5/8	59 7/8	22	56 1/4	8	5	2	1	--
1201	68 1/4	49 5/8	59 7/8	22	56 1/4	8	5	2	1	--
1501	58 1/8	38 1/4	48 5/8	16 3/8	45 7/8	10	5	2 1/2	1 1/4	--
1751	62 5/8	42 5/8	53 1/8	16 3/8	50 3/8	10	5	2 1/2	1 1/4	--
2001	66 7/8	46 7/8	57 3/8	20	53 5/8	12	5	3	1 1/4	--
2501	73 1/2	52 5/8	63 5/8	25 3/4	60 3/8	12	5 1/2	3	1 1/2	--
3001	79 1/2	58 5/8	69 5/8	31 3/4	66 3/8	12	5 1/2	3	1 1/2	--
3501	86 1/2	63 5/8	76	24 7/8	72 5/8	14	6	4	2	--
4001	91 1/2	68 5/8	81	29 7/8	77 5/8	14	6	4	2	--
4501	96 1/2	73 5/8	86	34 7/8	82 5/8	14	31	4	2 1/2	--
5001	101 1/2	78 5/8	91	39 7/8	87 5/8	14	31	4	2 1/2	--
4514	83	59 3/4	72 1/4	20 3/4	67 7/8	14	31	4	2 1/2	3 1/2
5014	88 1/4	65	77 1/2	26	72 1/4	14	31	4	2 1/2	3 1/2
6014	102	75 1/2	91	35 1/2	85 1/2	14	31	4	3	2 3/4

*Recommended pipe size. Models 1500-5000 Appliance Inlet/Outlet Connections are 3", all units are groove-locked type.

**Recommended size of air inlet pipe, actual air inlet opening at filter may be one size larger than shown

Primary Heat Exchanger Head Loss and Flow

Model	Temperature Rise Across Heat Exchanger			
	20°F		30°F	
	USGPM	ΔP-Ft.	USGPM	ΔP-Ft.
0501	42.0	1.5	28.0	0.7
0751	63.0	3.0	42.0	1.4
1101	92.4	5.9	61.6	2.8
1201	102.0	4.4	68.0	2.0
1501	125.9	8.3	83.9	3.8
1751	135.0	12.5	90.0	6.0
2001	167.9	6.7	111.9	3.2
2501	209.9	8.4	139.9	3.9
3001	251.9	9.9	167.9	4.7
3501	297.2	11.8	198.1	5.6
4001	340.4	17.1	226.9	8.1
4501	382.1	28.4	254.7	13.3
5001	424.4	31.1	282.9	14.7
4514	382.1	20.4	254.7	9.7
5014	424.4	23.5	282.9	11.2
6014	509.3	38.0	339.5	18.0

Non-Condensing Venting

Model	Vent ("V") Diameter Inches			
	Outdoor	Cat. IV Up to 50 ft	Cat. IV Up to 100 ft	Cat. II
0501	4	4	6	5
0751	6	6	8	6
1101	6	6	8	7
1201	6	6	8	7
1501	7	7	10	8
1751	7	7	10	8
2001	8	8	12	9
2501	8	8	12	9
3001	8	8	12	10
3501	9	9	14	12
4001	9	9	14	12
4501	10	10	14	12
5001	10	10	14	12
4514	10	10	14	12
5014	10	10	14	12
6014	12	12	14	12

Input & Output (MBTUH)

Model	Near-Condensing	
	Input	Output
0501	500	440
0751	750	660
1101	1100	968
1201	1200	1056
1501	1500	1320
1751	1750	1540
2001	2000	1760
2501	2500	2200
3001	3000	2640
3501	3500	3080
4001	4000	3520
4501	4500	3960
5001	4999	4399
4514	4500	3960
5014	4999	4399
6014	6000	5280

Shipping Weight (LBS)

Model	Near-Condensing
0501	520
0751	600
1101	640
1201	700
1501	825
1751	900
2001	943
2501	1,025
3001	1,100
3501	1,250
4001	1,290
4501	1,420
5001	1,627
4514	1,525
5014	1,732
6014	1,963

Current drawn by Boiler @ 115 Volts Single Phase 60 Hz

Model	Max Amps Draw – Boiler Only
0501	7
0751	7
1101	7
1201	7
1501	11
1751	11
2001	11
2501	14

Current drawn by Boiler @ 230 Volts 60 Hz

Model	Max Amps Draw – Boiler Only	Phase
3001	14	Single
3501	16	Single
4001	16	Single
4501	24	Single
5001	18	Three
4514	24	Single
5014	18	Three
6014	18	Three

Model #: _____ # Of Units: _____ Type of Gas: _____ Total Input _____ BTU/hr

Total Output _____ BTU/hr Flow _____ USGPM @ Allowable Pressure Drop _____ Ft.

Optional Accessories: _____